

Specifications

Output Power HP (kW)	25 (18.5)
Phase	3 Phase
Pole	4 Pole
Frame Number	180M

Degrees of Protection	IP 55
Enclosure Construction	Totally-enclosed Fan-cooled
Thermal Class	Class F (155 °C)

Alignment	Vertical
Frame Material	Steel plate

Power Transmission	Direct-couple or Belt Driven
Direction of Rotation	Counterclockwise (CCW) viewed from shaft-end side



Connection Type	Terminal Block (6 Leads)
Coating Colour	Munsell N5.5 (Gray)
Conformed Standard	IEC 60034-1 & JEC-2137-2000



Voltage & Frequency	HT Type
	380~415V 50Hz 380~440V 60Hz (suitable for γ - Δ starting)

Dimensions (mm)

Flange Number	Motor								
	D	IE	LA	LB	LC	LE	LG	LL	LZ
FF350	376	247	350	300 j6	400	5	20	576	18.5

Terminal Box			Shaft End						
KD	KG	KL	LR	Q	QK	S	T	U	W
PF 1 1/2	176	284	110	110	90	48 k6	9	5.5	14

Bearing No.		Approximated Weight (kg)	Approximated Packing Dimensions (LxWxH)	Gross Weight (kg)
Drive End	Opposite			
6311ZZ	6310ZZ	190	854 x 652 x 610	217

Connection & Connection Diagram

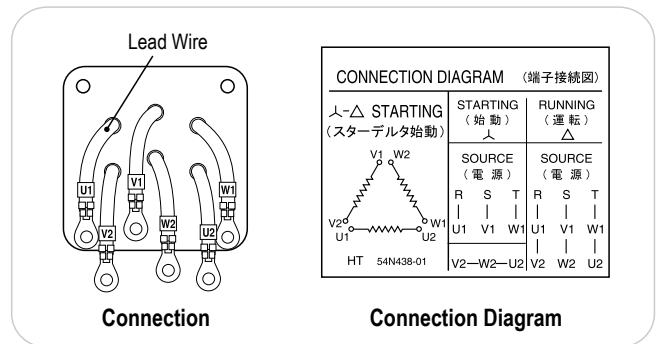

Circumstance Conditions

Ambient Temperature	-20 ~ +40°C
Ambient Humidity	95% RH or less
Operating Altitude	Less than 1,000m above sea level
Environment	No bursting / erosive gas or vapor

Motor Characteristics

Type	Hz	V	50% Load			75% Load			100% Load				Torque(%)		Is (A)	Inertia GD ² (kg-m ²)	
			(A)	Eff(%)	PF(%)	(A)	Eff(%)	PF(%)	(A)	Eff(%)	PF(%)	Speed (r/min)	Torque (kg-m)	Ts			Tm
HT	50	380	20.5	0.90	0.76	27.4	0.91	0.85	35.1	0.91	0.89	1460	12.34	300	280	255	0.63
		415	22.0	0.87	0.67	27.4	0.89	0.80	33.6	0.90	0.86	1470	12.26	365	337	278	
	60	380	18.6	0.90	0.84	25.9	0.91	0.89	34.0	0.91	0.91	1750	10.30	247	250	210	
		440	18.4	0.89	0.74	23.8	0.91	0.84	30.5	0.91	0.88	1760	10.24	338	340	244	